

	Technical Customer Information	ki0503e0
	Menu structure for the 'FU-Control' 954L5098 + 954L5100 + 954L5099	16.02.2012 Page: 1 of 8

1 Summary of contents

This customer information describes the menu structure in combination with the inverters DSV/GSV 5445/5444 using the external FU-Control (954L5098, 954L5099 without fault-memory and 954L5100, 954L5101 with a fault-memory over EEprom). The meaning of parameters, variables, etc. with details and notes you will find in manual **EMOTRON/CG DSV 5445/5444 LIFT (02/12)** or in application-notes.

2 954L5098, 954L5099 und 954L5100, 954L5101 (permanent fault-history over internal EEprom)

You can choose between two different versions of the external FU Control. The articles 954L5098 and 954L5099 support no EEprom, the articles 954L5100 and 954L5101 support the integrated EEprom, which is able to save failure-notes during 'power-off' in the 'FUCT'. Those messages can be read out after next 'power-on'. The article 954L5100 and 954L5101 have the additional menu 'fault history view or erase from FUCT'. The 954L5098 and 954L5099 has only the function 'fault history view or erase from DSV', if EEprom is not soldered/placed. An EEprom can be added later (upgrade to 954L51xx).

2.1 The new SMD-version of 'FU-Control' (954L5098, 099, 100, and 954L5101)

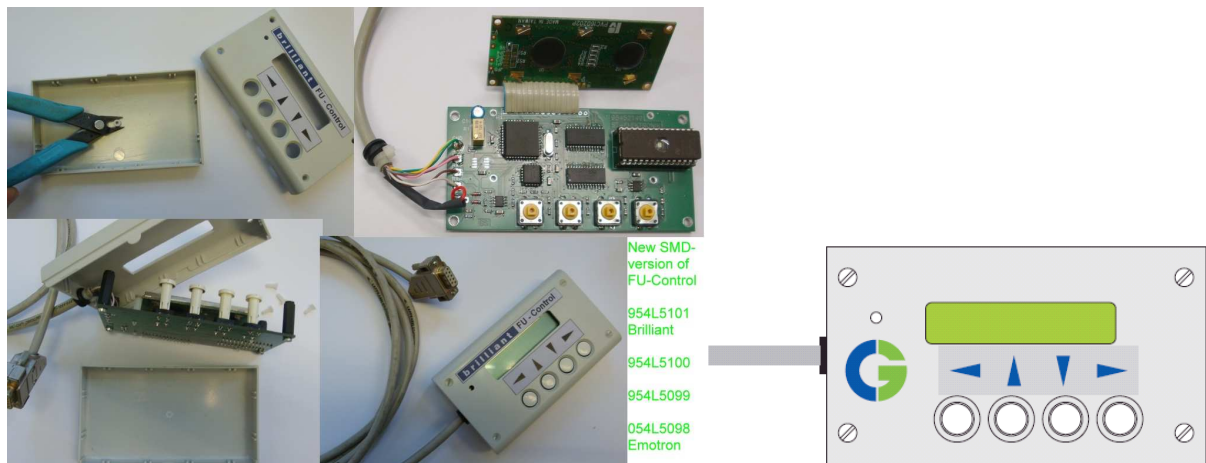

Note: Firmware 'FUC_BLT.BIN/.HEX' (at least from version 3.0) was only made for 954L5101 for BLT, all other firmware 'FUC_SMD.BIN/.HEX' (at least from version 3.5) are made for 954L5098 up to 954L5101 but support only the parallel EEprom (for serial the version must be 4.x and those kind of boards will have different partlist. Only version 4.x will support full kom-program -up / -download later).

2.2 Operation in using the four arrow-keys below the 2x16-line-LC-display:



left button = escape, mid button = up/down, right button = enter!

 Manual for the 'FU-Control'	Technical Customer Information	kl0503e0
	Menu structure for the 'FU-Control' 954L5098 + 954L5100 + 954L5099	16.02.2012 Page: 2 of 8

3 Menu structure for external FU-control (external control to '5444/5445')

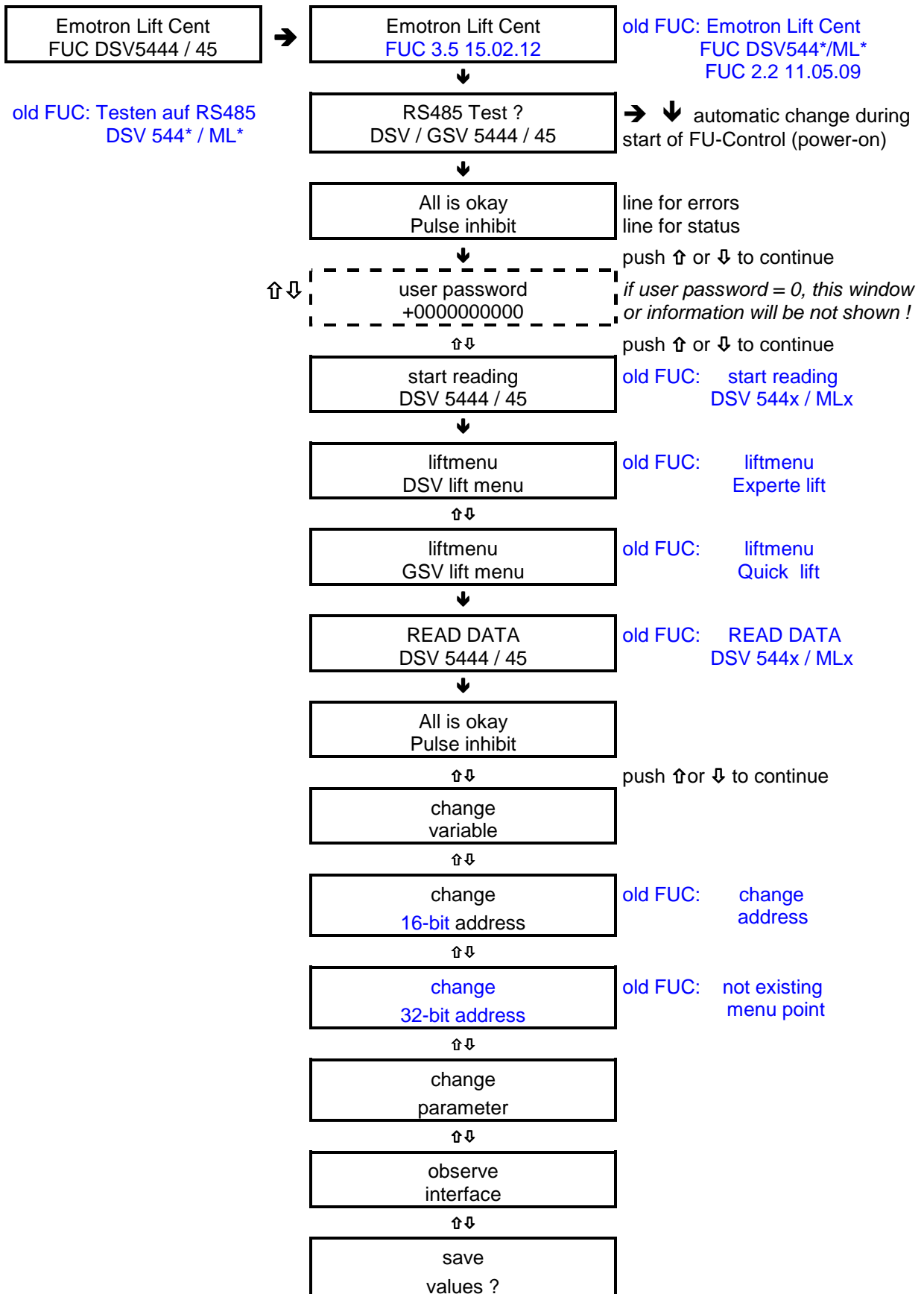

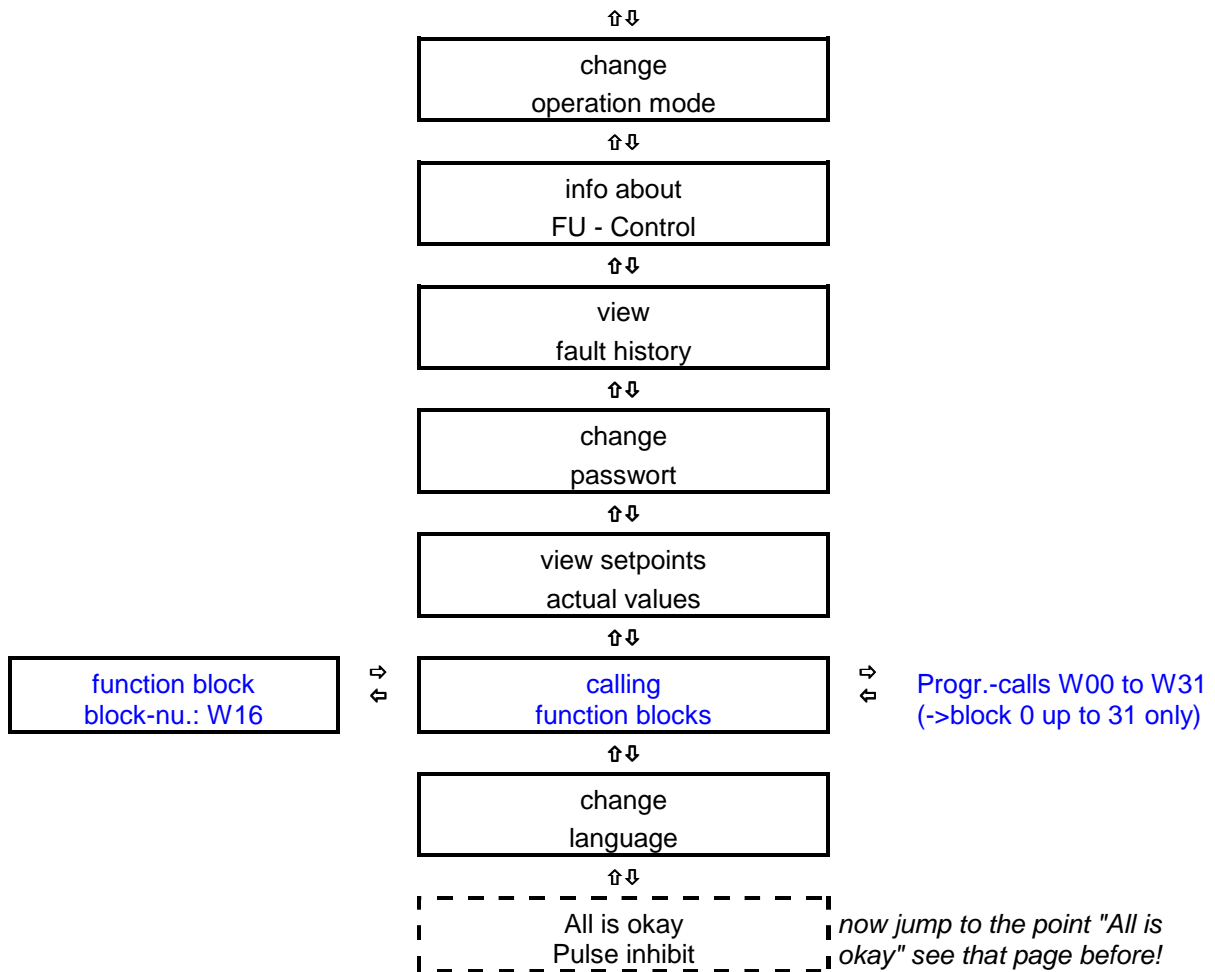

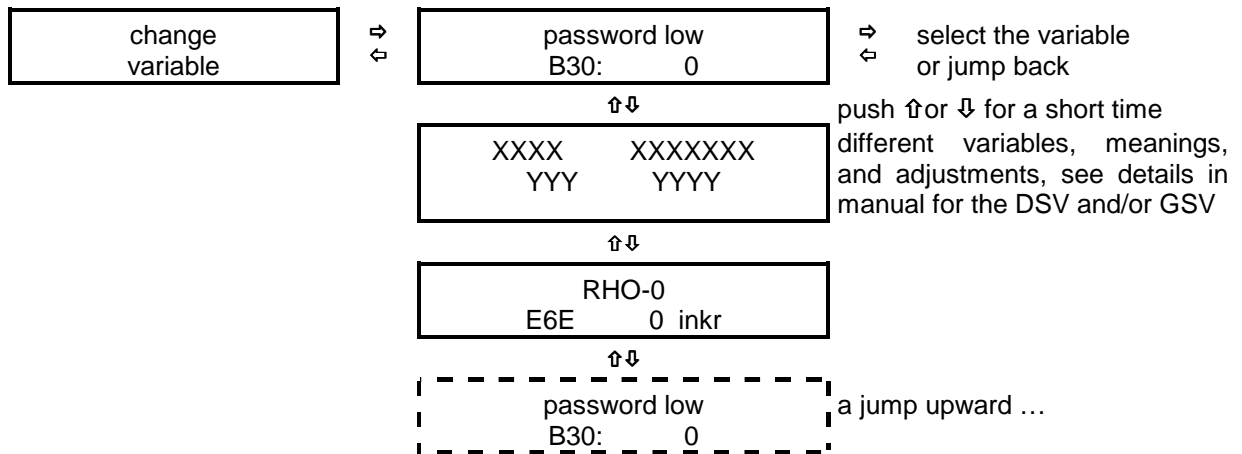

3.1 Menu structure 2. level "change variable"

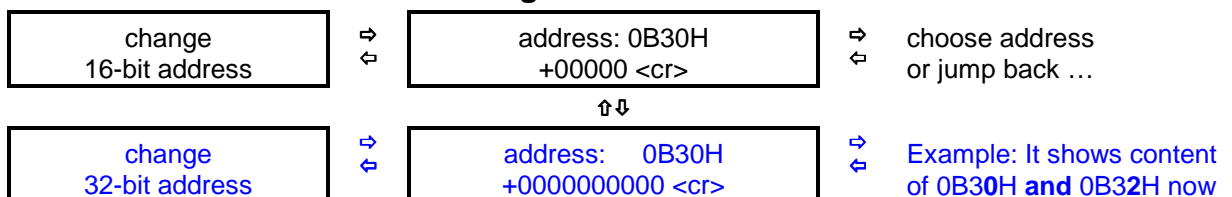

3.2 Menu structure 2. level "change adresse"



 Manual for the 'FU-Control'	Technical Customer Information	kl0503e0
	Menu structure for the 'FU-Control' 954L5098 + 954L5100 + 954L5099	16.02.2012 Page: 4 of 8

3.3 Menu structure 2. level "change parameter"

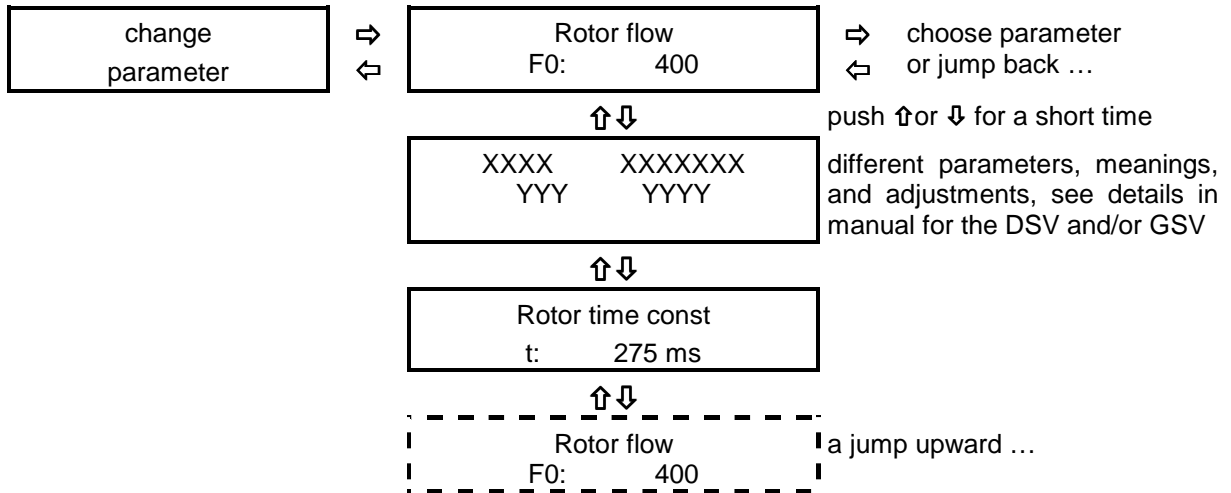

3.4 Menu structure 2. level "observe interface"

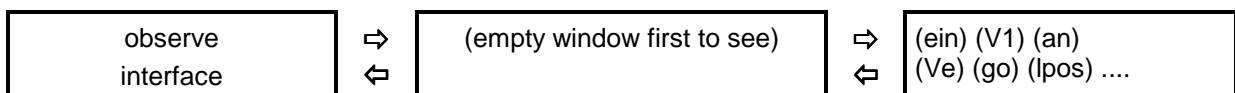

3.5 Menu structure 2. level "save values"

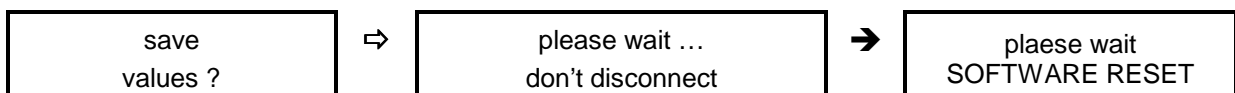

3.6 Menu structure 2. level "change operation mode"

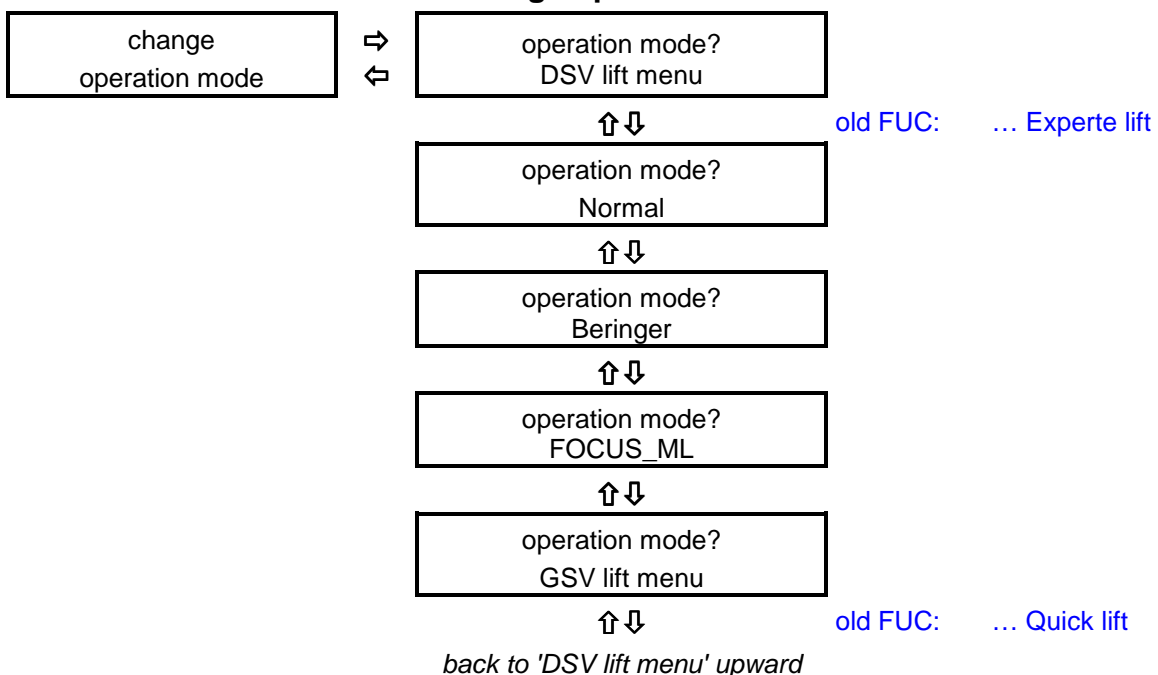

 Manual for the 'FU-Control'	Technical Customer Information	kl0503e0
	Menu structure for the 'FU-Control' 954L5098 + 954L5100 + 954L5099	16.02.2012 Page: 5 of 8

3.7 Menu structure 2. level "Info about FU-Control"

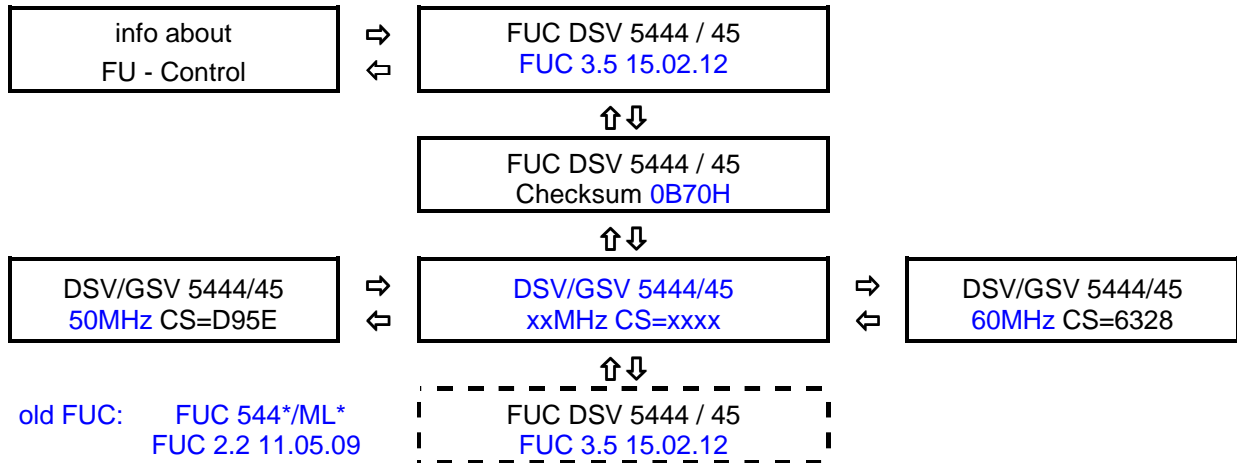

3.8 Menu structure 2. level "view fault history"

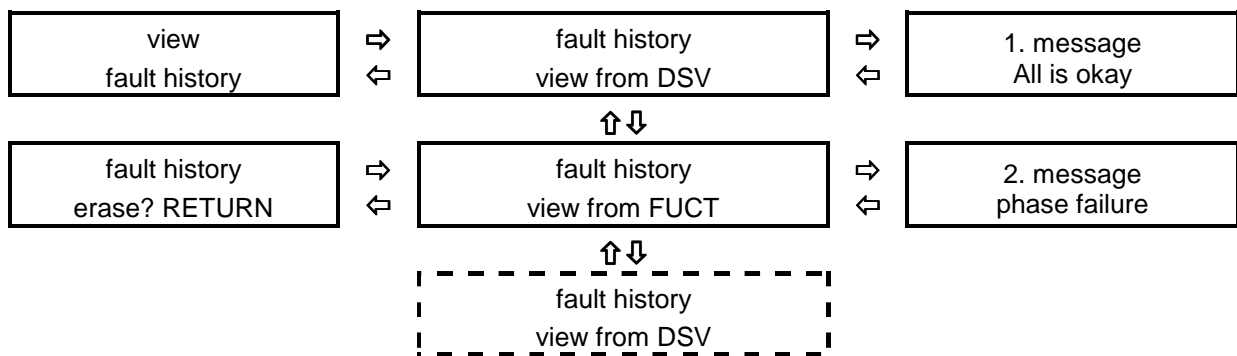

3.9 Menu structure 2. level "change password"

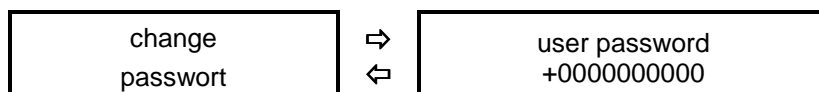

 Manual for the 'FU-Control'	Technical Customer Information	kl0503e0
	Menu structure for the 'FU-Control' 954L5098 + 954L5100 + 954L5099	16.02.2012 Page: 6 of 8

3.10 Menu structure 2. level "view setpoints" for normal FU-Control

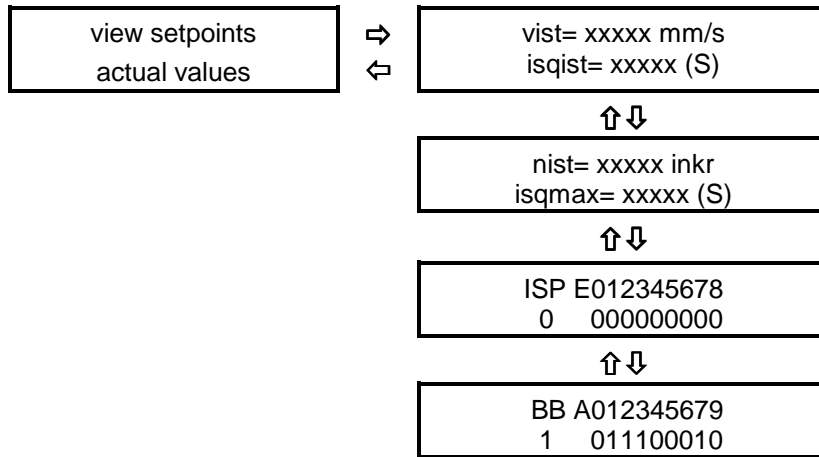

3.11 Menu structure 2. level "change language" for normal FU-Control

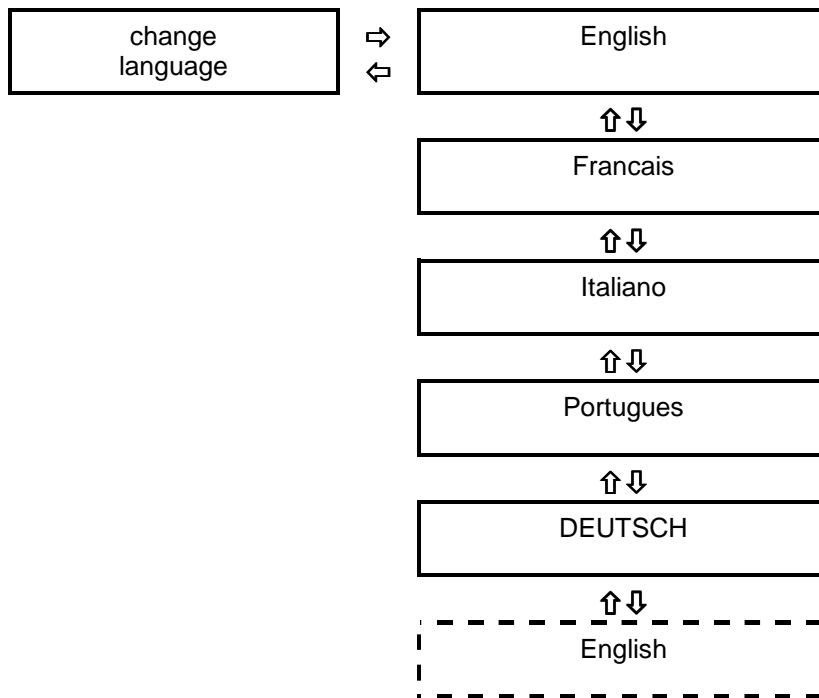

Note: To set the FUCT default to the correct language during producing/testing-process of inverter, the address 9FFFh can be set over EmoSoftLift-terminal-function (value 2 = English, value 1 = DEUTSCH)

Note: In some cases the shown words in the FU-Control have not the fully correct spelling (example are: "adresse" or "passwort" instead "address" or "password", these have software-reasons in 'V2.2')!

Next page shows some different in menu in case of newer smd-version of the FUC will be used:

3.12 Menu structure 2. level "view setpoints" in case of new smd-version V3.x

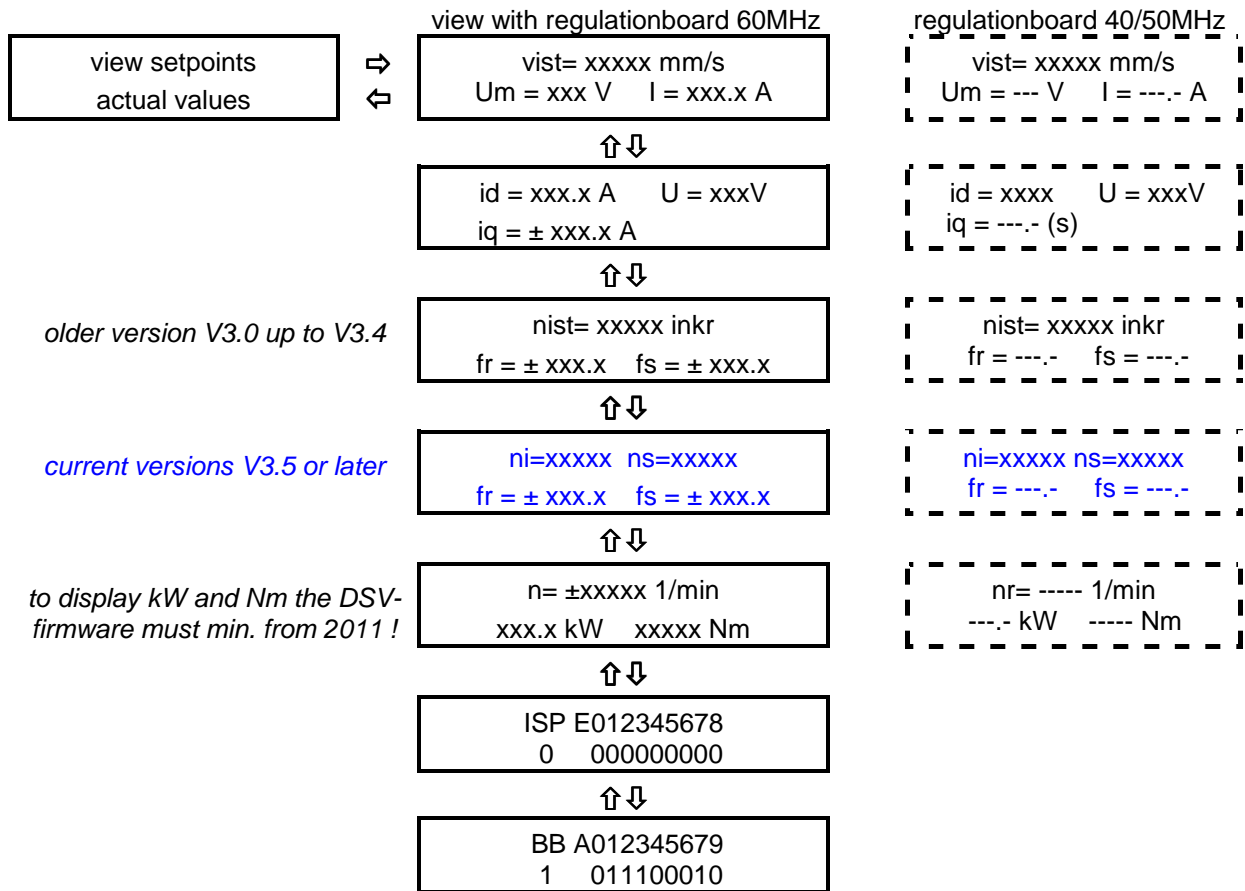

var.	unit	10A	15A	20A	30A	40A	40A	50A	60A	80A	80A	120A	150A	200A	250A	320A	400A	3A	6A	9A	12A	16A	25A	32A	45A	
0e30h		1000	1000	1500	953	2000	1000	1500	665	487	487	300	267	200	150	124	100	1000	1000	1000	1000	1000	1000	1000	1000	1000
0e32h		500	500	1000	1000	2000	1000	2000	1000	1000	1000	1000	1000	1000	1000	1000	1000	125	250	500	500	1000	1000	1000	1000	
BGR		1	1	2	2	3	3	3	3	3	4	4	4	5	5	5	5	1	1	1	1	2	2	2	3	
Firmware		04N	05N	05N	05N	06N	06N	06N	06N	06N	06N	06N	06N	06N	06N	06N	06N	A3N	A3N	A2N	A3N	A2N	A3N	A4N	A5N	
Serie Amp		40	48	48	48	60	60	60	60	60	60	60	60	60	60	60	60	32	32	28	32	28	32	40	48	
Ur84 Volt		9	9	9	7,6	10	9	10	5	5	10	10	5,4	5,6	4,25	4,7	3,1	11	8	7	9	6	8	8	11	
R-shunt Ohm		100	100	150	95,3	200	100	150	66,5	48,7	48,7	30	26,7	20	15	12,4	6,65	100	100	100	100	100	100	100	100	
R-gate Ohm		56,2	56,2	39,2	27,4	22,1	22,1	15	15	10	15	5,62	4,7	3,32	3,32	2,74	2,74	82,5	82,5	68,1	56,2	39,2	39,2	27,4	22,1	
Wdg current		2	2	1	1	1	1	1	1	1	1	1	1	1	1	1	1	8	4	2	2	1	1	1	1	
R-reg K-Ohm		33,2	33,2	33,2	33,2	33,2	33,2	33,2	66,5	66,5	33,2	33,2	66,5	66,5	66,5	66,5	100	33,2	33,2	33,2	33,2	33,2	33,2	33,2	33,2	
Lem/VAC		1000	1000	1000	1000	2000	1000	2000	2000	2000	1000	1000	2000	2000	2000	2000	2000	1000	1000	1000	1000	1000	1000	1000	1000	
max. kHz		15	12	12	12	12	12	12	12	10	10	5,0	5,0	5,0	2,5	2,5	2,5	5,0	5,0	5,0	5,0	5,0	5,0	5,0	5,0	
R96 K-Ohm															4,75	4,75	4,75									
f24 60MHz		1	1	1	1	1	1	1	2	2	1	1	2	2	2	2	3	1	1	1	1	1	1	1	1	
CNYD-Type:		10A	12A	15A	25A	30A		40A	45A	60A																
nominal A		10	12	15	25	30		40	45	60																
dynamic A		20	24	30	50	60		80	90	120																
case-form		1	1	2	2	3		3	3	3																
max. kHz		15	12	12	12	12		12	12	10															4GB	

0e30h means "current shunt" value given in "Ohm * 10"

0e32h means "current sensor Kn" (given without factor)

Parameter F24 has to be set correct in case the value of variable 0e60h is set to '-256' (encoder-less)

 Manual for the 'FU-Control'	Technical Customer Information	kl0503e0
	Menu structure for the 'FU-Control' 954L5098 + 954L5100 + 954L5099	16.02.2012 Page: 8 of 8

3.13 Menu structure 1. level "main menu" in case of new smd-version CNYD

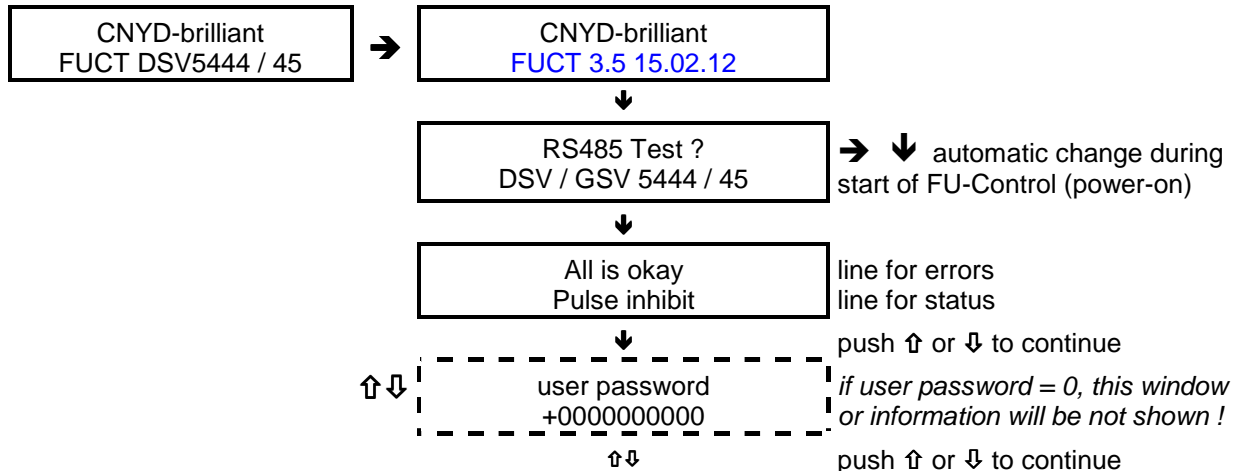

all next lines are the same as in the top of this document for the normal older FU-Control is shown here
Note: The new SMD-version is always with EEprom, the new order-code / article-number is: 954L5101!

3.14 Menu structure 0. level "Power-On-Service" using SMD-FUC with EEprom

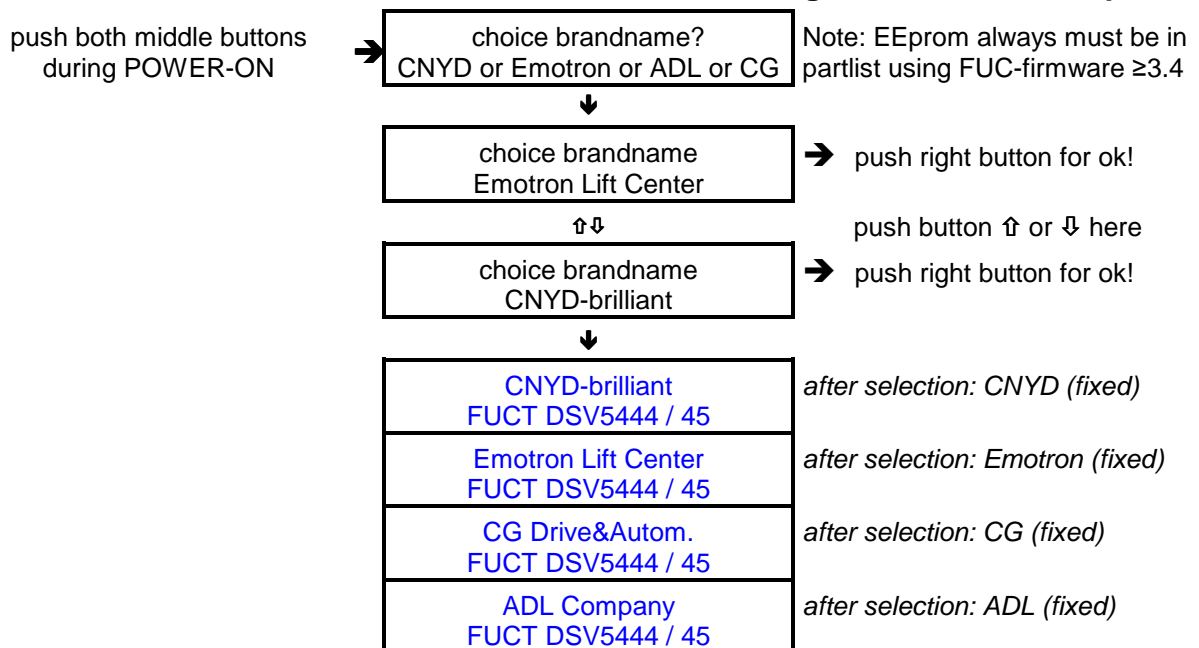

This step has do be done only one time during testing- or production-people on site Emotron, CG, BLT!

4 Upgrade older 954L5098 to 954L5100 (socket must be existing in FUCT)



(picture shows how to place the-EEproms into the old FU-Control)

Note: Firmware 'FUC_EXT.BIN/.HEX' (at least from version 2.2) ist the same for both types of FUCT. An added or removed EEprom will be automatically detected by the firmware 2.2 (so it's nothing to do).